



# JRS ARCHITECT, P.C.

ARCHITECTURE

INTERIOR DESIGN

PRESERVATION

## PRINCIPALS

JOHN R.  
SORRENTI, FAIA, FRAIC  
President

ALEXANDER  
HADJIYANE, AIA  
Senior Vice President

ROBERT S.  
MORRISEY, AIA  
Vice President

## ASSOCIATES

FRANCES  
CONSOLI, AIA  
LEED AP

CHRIS  
RUDMAN, AIA  
LEED AP

JOHN G.  
COLLINS  
Director of IT

# PROJECT MANUAL

## Montclair State University

## University Hall – Roof Renovation Montclair, NJ

DATE: April 4, 2025

PROJECT NO. 25001.00

## OFFICES

NEW YORK  
181 East Jericho Turnpike  
Mineola, NY 11501  
T 516 294-1666  
F 516 294-1669

NEW JERSEY  
116 Village Boulevard  
Suite 304  
Princeton, NJ 08540  
T 609 688-9100  
F 609 688-9060

[www.jrsarchitect.com](http://www.jrsarchitect.com)

**University Hall Roof Renovation  
Montclair State University**

---

**TABLE OF CONTENTS**

**DIVISION 01 - GENERAL REQUIREMENTS**

01 1100 Summary of Work

**DIVISION 02 - EXISTING CONDITIONS**

02 4120 Selective Building Demolition

**DIVISION 07 - THERMAL AND MOISTURE PROTECTION**

07 5300 Thermoset (EPDM) Membrane Roofing

\*Refer to drawings for additional information

END OF TABLE OF CONTENTS

**University Hall Roof Renovation  
Montclair State University**

---

**SECTION 01 1100**

**SUMMARY OF WORK**

**PART 1 GENERAL**

1.1 SUMMARY

- A. Section Includes:
1. Project description.

1.2 PROJECT DESCRIPTION

- A. Work of this Project is described as the roof renovation to an existing multi story building entitled University Hall located at Montclair State University. This is a lower level roof on the building above the second floor.
- B. The project "Roof Renovation" includes the work as shown on the drawings and described in the specifications. The second-floor roof on the South part of this building is the only roof in the scope of work. The project calls for complete removal of the existing EPDM membrane, plywood cover board and poly-iso insulation down to the concrete deck. The proposed roofing system will include a new ½" cover board all components are adhered with the specified adhesive and completed with a fully adhered 145 mil VersiFleece RapidLock (RL) VersiGard EPDM membrane. The existing perimeter cast stone coping will remain. The existing Counterflashing on the entire perimeter of the roof will remain. At the existing stucco walls and parapet, the existing counter flashing will be reused, and the new membrane shall be terminated under this flashing. The existing roof pavers shall be removed and discarded. The existing sealant joint above the existing counter flashing shall be replaced. All sealant joints related to the roofing shall be replaced with new to leave a watertight installation.
- C. Phasing: Only remove the amount of roofing that can be replaced in that same day
- D. The work is to be conducted on student and staff occupied premises. The work must be conducted in such a manner as to minimally interfere with the operation of MSU.

**PART 2 PRODUCTS**

- A. Product Selections: Comply with the following selection of products, materials and equipment:
1. Single Product Named: Provide that product or approved equal that meets or exceeds the specified product. Any proposed substitutions must be submitted prior to deadline of questions.
  2. Refer to Part 2 - 2.1 Manufactures for requirements for substitutions.

END OF SECTION

**University Hall Roof Renovation  
Montclair State University**

---

**SECTION 02 4120**

**DEMOLITION**

**PART 1 GENERAL**

**1.1 SUMMARY**

- A. Section Includes:
  - 1. Removal of designated building construction, equipment, and fixtures.
- B. Related Sections:
  - 1. Division 01 - Administrative, procedural, and temporary work requirements.

**1.2 SUBMITTALS**

- A. Submittals for Review:
  - 1. Shop Drawings: Indicate areas for demolition, removal sequence and location of salvageable items, and location and construction of temporary work.

**1.3 REGULATORY REQUIREMENTS**

- A. Conform to applicable code for demolition work, safety of structure, and dust control.
- B. Obtain required permits from authorities.
- C. Notify affected utility companies before starting work and comply with their requirements.
- D. Conform to applicable codes when hazardous or contaminated materials are discovered.
- E. Do not close or obstruct exits.
- F. Do not disable or disrupt building fire or life safety systems without [3] days prior written notice to Owner.
- G. Abide by all OSHA standards rules for health and safety.

**1.4 PROJECT CONDITIONS**

- A. Minimize interference with streets, walks, public right-of-ways, and adjacent facilities.
- B. If hazardous materials are discovered, notify [Architect] and await instructions.
- C. If any of the following conditions are encountered, cease work immediately, notify [Architect,] and await instructions:
  - 1. Structure is in danger of movement or collapse.
  - 2. Materials or conditions encountered differ from those designated in the Contract Documents.
- D. All cranes and related heavy equipment to complete the specified work are to be provided by the Contractor.

**JRS ARCHITECT, P.C.**

[www.jrsarchitect.com](http://www.jrsarchitect.com)

**University Hall Roof Renovation  
Montclair State University**

---

**PART 2 PRODUCTS**

Not used

**PART 3 EXECUTION**

**3.1 PREPARATION**

- A. Erect temporary partitions, barricades, warning devices, and controls where required.
- B. Provide protective coverings for construction designated to remain.
- C. Temporarily or permanently disconnect utilities as required.

**3.2 DEMOLITION**

- A. Remove existing construction to extent indicated on contract drawings and as necessary to join new work to existing. Do not remove more than is necessary to allow for new construction.
- B. Do not damage work designated to remain.
- C. Minimize noise and spread of dirt and dust.
- D. Assign work to trades skilled in procedures involved.
- E. Plug ends of disconnected utilities with threaded or welded caps.
- F. Protect and support active utilities designated to remain. Post warning signs showing location and type of utility and type of hazard.
- G. Store items designated to remain property of Owner where directed by [Owner].
- H. Remove and dispose of waste materials off site.

END OF SECTION

**University Hall Roof Renovation  
Montclair State University**

---

**SECTION 07 53 – THERMOSET, EPDM, MEMBRANE ROOFING**

**PART 1 GENERAL**

**1.1 SECTION INCLUDES**

- A. Thermoset Membrane Roofing.
- B. Membrane Flashings.
- C. Metal Flashings.
- D. Roof Insulation.

**1.2 RELATED SECTIONS**

- A. Section 22 30 00 - Plumbing Equipment.

**1.3 REFERENCES**

- A. American Society of Civil Engineers (ASCE) - ASCE 7 - Minimum Design Loads for Buildings and Other Structures, Current Revision.
- B. ASTM International (ASTM):
  - 1. ASTM C 1289 - Standard Specification for Faced Rigid Cellular Polyisocyanurate Thermal Insulation Board.
  - 2. ASTM D 412 - Standard Test Methods for Vulcanized Rubber and Thermoplastic Elastomers-Tension.
  - 3. ASTM D 624 - Standard Test Method for Tear Strength of Conventional Vulcanized Rubber and Thermoplastic Elastomers.
  - 4. ASTM D 4637 - Standard Specification for EPDM Sheet Used In Single-Ply Roof Membrane.
  - 5. ASTM E 96 - Standard Test Methods for Water Vapor Transmission of Materials.
- C. Factory Mutual (FM Global):
  - 1. Approval Guide.
    - a. Roof NAV 430413-0-0
    - b. Factory Mutual Standard 4470 - Approval Standard for Class 1 Roof Covers.
    - c. Loss Prevention Data Sheets 1-28, 1-29.
- D. International Code Council (ICC):
  - 1. International Building Code (IBC).
- E. Underwriters Laboratories (UL):
  - 1. TGFU R1306 - "Roofing Systems and Materials Guide".
  - 2. UL-790 - Standard Test Method for Fire Tests of Roof Coverings.

**1.4 DESIGN CRITERIA**

- A. Wind Uplift Performance:
  - 1. Roof system is designed to achieve a FM 1 285 wind uplift rating.

**University Hall Roof Renovation  
Montclair State University**

---

B.Fire Resistance Performance:

- 1.Roof system will achieve a UL Class A rating when tested in accordance with UL-790.

C.Thermal Performance: Refer to contract drawings.

D.Drainage: Provide a roof system with positive drainage where all standing water dissipates within 48 hours after precipitation ends.

E.Building Codes:

- 1.Roof system will meet the requirements of all federal, state and local code bodies having jurisdiction.

### 1.5 SUBMITTALS

A.Product Data: Manufacturer's data sheets on each product to be used, including:

- 1.Preparation instructions and recommendations.
- 2.Storage and handling requirements and recommendations.
- 3.Installation methods.

B.Selection Samples: For each finish product specified, two complete sets of chips representing manufacturer's full range of available colors, membranes, and thicknesses.

C.Verification Samples: For each finish product specified, two samples, minimum size 4 inches (102 mm) square representing actual product, color, and patterns.

### 1.6 QUALITY ASSURANCE

A.Manufacturer Qualifications: All primary products specified in this section will be supplied by a single manufacturer with a minimum of fifteen (15) years experience.

B.Installer Qualifications:

- 1.All products listed in this section are to be installed by a single installer with a minimum of five (5) years demonstrated experience in installing products of the same type and scope as specified.
- 2.Installer shall be capable of extending the Manufacturer's No Dollar Limit guarantee.

### 1.7 DELIVERY, STORAGE, AND HANDLING

A.Store products in manufacturer's unopened packaging until ready for installation.

B.Store and dispose of hazardous materials, and materials contaminated by hazardous materials, in accordance with requirements of local authorities having jurisdiction.

C.When loading materials onto the roof, comply with the requirements of Owner to prevent overloading and possible disturbance to the building structure.

D.Contaminants such as grease, fats and oils shall not be allowed to come in direct contact with the roofing membrane.

### 1.8 PROJECT CONDITIONS

A.Maintain environmental conditions (temperature, humidity, and ventilation) within limits recommended by manufacturer for optimum results. Do not install products under environmental conditions outside manufacturer's absolute limits.

**University Hall Roof Renovation  
Montclair State University**

---

B.Refer to manufacturer's recommendations for general job site considerations.

C.Safety Data Sheets (SDS) must be on location at all times during the transportation, storage and application of materials.

D.Proceed with work so new roofing materials are not subject to construction traffic. When necessary, new roof sections shall be protected and inspected upon completion for possible damage.

E.New roofing shall be complete and weathertight at the end of the work day.

#### 1.9 WARRANTY

A.At project closeout, provide to Owner or Owners Representative an executed copy of the manufacturer's Total-System warranty, outlining its terms, conditions, and exclusions from coverage.

1.Duration: Thirty (30) years.

2.Puncture Coverage Rider: Coverage to be extended to include accidental punctures in accordance with terms stated in the Warranty document.

3.Hail Coverage Rider: Coverage to be extended to include damage caused by a maximum 1 inch (25 mm) diameter hail in accordance with terms stated in the Warranty document.

4.Coverage to be extended to include roof edge metal water tightness in accordance with terms stated in the Warranty document.

#### PART 2 PRODUCTS

##### 2.1 MANUFACTURERS

A.Acceptable Manufacturer: Versico Roofing Systems, which is located at: P. O. Box 1289; Carlisle, PA 17013; Toll Free Tel: 800-992-7663; Fax: 717-960-4036; Email:[bcostanzo@eastcoastroof.net](mailto:bcostanzo@eastcoastroof.net);  
Web:<http://www.versico.com>

B.Approved Equal

##### 2.2 SCOPE / APPLICATION

A.Roof System: Provide a waterproof roof system, capable of withstanding uplift forces as specified in this section.

1.Membrane Attachment: Fully Adhered.

B.Base Flashing: Provide a waterproof, fully adhered base flashing system at all penetrations, plane transitions and terminations.

C.Insulation: Provide a roof insulation system beneath the finish membrane.

##### 2.3 INSULATION

A.Polyisocyanurate MP-H: Versicore MPH. Rigid board with glass fiber reinforced (GRF) facers on both sides, meeting or exceeding the requirements of ASTM C 1289, Type II, Class 1.

1.Compressive Strength: Grade 2 (20 psi) (138 kPa).

2.Density: 2 lb per cubic foot (24 kg per cu m) minimum.

B.Versico SecurShield HD RL Cover Board– a rigid insulation panel composed of a high-density, closed-cell polyisocyanurate foam core laminated to moisture resistant coated-glass fiber-mat facer for use as a cover board or recover board meeting ASTM 1289, Type II, Class 4, Grade 1 (80 psi). Available

**University Hall Roof Renovation  
Montclair State University**

---

1/2" thick 4' x 8' panel weight 11 lbs with an R-value of 2.5. SecurShield HD RL has an additional "hook" facer to be used with the "loop" fleece of the VersiFleece RL membrane.

#### 2.4 INSULATION ADHESIVE

A.Flexible DASH Dual Tank Adhesive: A two-component, polyurethane construction grade, low-rise expanding adhesive designed for bonding insulation to various substrates using a portable applicator.

#### 2.5 ETHYLENE, PROPYLENE, DIENE TERPOLYMER (EPDM) MEMBRANE

2.6 Furnish VersiFleece RapidLock (RL) VersiGard (EPDM) 145-mil membrane. The membrane shall conform to the minimum physical properties of ASTM D4637-96, Type III (Fabric-backed membrane). Membrane sheets are 10' wide and 100' long and incorporate factory-applied splice tape (FAT) along the length of the membrane.

A.Dynamic Puncture Resistance (ASTM D5635-04a) of 35 joules for 145-mil.

B.Static Puncture Resistance (ASTM D120) of 28 lbf for 145-mil.

C.Color: Black

#### 2.7 FLASHING ACCESSORIES

A.Versico Black QA Molded Pipe Seals: Factory applied QA tape on the deck flange, for use with VersiGard Black or White Roofing Systems.

B.VersiGard Pourable Sealer Pocket: Pre-fabricated Pourable Sealer Pocket consisting of a 2 inch (51 mm) wide plastic support strip with pre-applied, adhesive backed uncured EPDM Flashing.

C.VersiGard QA Inside/Outside Corner: A 7 inch by 9 inch (178 x 229 mm) precut 60-mil thick Uncured EPDM Flashing with a 30-mil (0.76 mm) pre-applied adhesive tape. Available in black and white.

D.VersiGard QA Coverstrip: A nominal 40-mil (1.1 mm) black, semi-cured EPDM membrane laminated to a nominal 30-mil (0.76 mm) cured, pre-applied adhesive tape for flashing gravel stops, metal edgings and Seam Fastening Plates.

E.VersiGard QA "T" Joint Covers: A factory cut 6 inch by 6 inch (152 mm x 152 mm) or 12 inch by 12 inch (304 mm x 304 mm) uncured 40-mil thick EPDM flashing laminated to a nominal 30-mil (0.76 mm) pre-applied adhesive tape, used to overlay field splice intersections and to cover field splices at angle changes.

F.VersiGard QA Uncured EPDM Flashing: 60-mil (1.5 mm) thick uncured EPDM Flashing laminated to a 30-mil (0.76 mm) pre-applied adhesive tape used in conjunction with VersiGard Primer as an option to VersiGard Uncured EPDM Flashing.

#### 2.8 CLEANERS, PRIMERS, ADHESIVES AND SEALANTS

A.CAV-GRIP 3V Low-VOC Aerosol Contact Adhesive/Primer: a low-VOC, methylene chloride-free adhesive/Primer.

B.Weathered Membrane Cleaner: Clear, solvent-based cleaner used to loosen and remove contaminants

**University Hall Roof Renovation  
Montclair State University**

---

from the surface of exposed EPDM membrane prior to the application of Seam Adhesive or EPDM Primer.

- C. Versico QA Seam Tape: 3 inch (76 mm) or 6 inch (152 mm) wide by 100 foot (30.5 M) long splice tape used for splicing adjoining sections of EPDM membrane. Complies with the South Coast Air Quality Management District Rule 1168.
- D. Low VOC EPDM Primer: a solvent based primer designed for one-step cleaning and priming of EPDM surfaces prior to installation of quick-applied products. This product complies with the less than 250 g per L VOC content requirements for the OTC Model Rule for Single-Ply Roofing Adhesives.
- E. Flexible DASH Dual Tank Adhesive: A spray applied, two-component, polyurethane construction grade, low-rise expanding adhesive used to securely bond Insulation to a variety of substrates.
- F. Water Cut-Off Mastic: A one-component, low viscosity, self wetting, Butyl blend mastic used as a compression sealing agent between EPDM membranes or uncured flashing and applicable substrates.
- G. Versico One-Part Pourable Sealer: A black, one-component, moisture curing, elastomeric polyether sealant used for attaching lightning rod bases and ground cable clips to the membrane surface and as a sealant around hard-to-flash penetrations such as clusters of pipes.

## 2.9 FASTENING COMPONENTS

- A. Seam Fastening Plate: 2 inch (51 mm) diameter metal fastening plate used for membrane and RTS attachment on Mechanically Attached Roofing Systems over wood or structural concrete decks. Seam Fastening Plates are also used in conjunction with RTS or EPDM membrane for additional membrane securement on Adhered or Ballasted Roofing Systems. This plate may be used for insulation attachment on Mechanically Attached Roofing Systems.
- B. Versico Fasteners:
  - 1. HPV Fastener: A threaded, black epoxy electro-deposition coated (E-Coat) fastener for use with steel, wood plank, minimum 15/32 inch (12mm) thick plywood or minimum 7/16 inch (11 mm) thick oriented strand board (Adhered Roofing Systems only).
  - 2. CD-10 Concrete Fastener: A hammer-driven, non-threaded, black epoxy electro-deposition coated (E-Coat) fastener for use with structural concrete decks rated 3,000 psi or greater.

## 2.10 EDGINGS AND TERMINATIONS

- A. Termination Bar: 1 inch (13 mm) wide, .098 inch (2.5 mm) thick extruded aluminum bar pre-punched 6 inches (152 mm) on center with sealant ledge to support Lap Sealant.

## PART 3 EXECUTION

### 3.1 EXAMINATION

- A. Do not begin installation until substrates have been properly prepared.
- B. The surface on which the insulation or roofing membrane is to be applied shall be clean, smooth, dry, and free of projections or contaminants that would prevent proper application of or be incompatible with the new installation, such as fins, sharp edges, foreign materials, oil and grease.

**University Hall Roof Renovation  
Montclair State University**

---

C.If substrate preparation is the responsibility of another installer, notify Architect of unsatisfactory preparation before proceeding.

### 3.2 PREPARATION

A.Clean surfaces thoroughly prior to installation.

B.Prepare surfaces using the methods recommended by the manufacturer for achieving the best result for the substrate under the project conditions.

C.Do not commence work until all other work trades have completed jobs that require them to traverse the deck on foot or with equipment.

D.A vapor retarder / temporary roof (Versico 725 TR Air and Vapor Barrier/Temporary Roof) may be applied to protect the inside of the structure prior to the roof system installation.

### 3.3 SUBSTRATE PREPARATION

A.Structural Concrete Deck:

- 1.Minimum deck thickness for structural concrete is 4 inches (102 mm).
- 2.Allow roof deck to cure prior to application of the roofing system. Where curing is in question, evaluate surface moisture and deck's dryness with the ASTM D-4263 or hot bitumen test procedures.
- 3.Repair cracks greater than 1/8 inch (3 mm) in width in accordance with the deck manufacturer's recommendations.
- 4.Sumps for the roof drains shall be provided in the casting of the deck.
- 5.Prime Surface with Cav Grip 3V

### 3.4 INSULATION - SYSTEM DESIGN.

A.Tapered System:

- 1.Type: Versicore Polyiso.
- 2.Starting Thickness. 1.5 inches at back of sump
- 3.Field Slope: 1/4 inch per ft.
- 4.Sump Slope: 1/2 inch per ft.
- 5.Attachment Method: Adhered in Flexible Dash 4" OC

B.Cover Board:

- 1.Type: Versico SecurShield HD RL
- 2.Thickness: 1/2 inch.
- 3.Attachment Method: Adhered in Flexible Dash 4" OC

### 3.5 INSULATION PLACEMENT

A.Install insulation or membrane underlayment over the substrate with boards butted tightly together with no joints or gaps greater than 1/4 inch (6 mm). Stagger joints both horizontally and vertically if multiple layers are provided.

B.Secure insulation to the substrate with the required mechanical fasteners or insulation adhesive in accordance with the manufacturer's current application guidelines.

C.Do not install wet, damaged or warped insulation boards.

**University Hall Roof Renovation  
Montclair State University**

---

- D. Stagger joints in one direction unless joints are to be taped. Install insulation boards snug. Gaps between board joints shall not exceed 1/4 inch (6 mm). Fill all gaps in excess of 1/4 inch (6 mm) with same insulation material.
- E. Wood nailers shall be at least 3-1/2 inches (89 mm) wide or 1 inch (25 mm) wider than adjacent metal flange. Thickness shall equal that of insulation but not less than 1 inch (25 mm) thickness.
- F. Miter and fill the edges of the insulation boards at ridges, valleys and other changes in plane to prevent open joints or irregular surfaces. Avoid breaking or crushing of the insulation at the corners.
- G. Do not install any more insulation than will be completely waterproofed each day.

### 3.6 INSULATION ATTACHMENT

- A. Securely attach insulation to the roof deck for Adhered Roofing Systems. Attachment shall have been successfully tested to meet or exceed the calculated uplift pressure required by the International Building Code (ASCE-7) or ANSI/SPRI WD-1.
- B. Enhance the perimeter and corner areas in accordance with FM Loss Prevention Data Sheet 1-29.
- C. Install insulation layers applied with adhesive, coverage rate as necessary to achieve the specified attachment and uplift rating. Press each board firmly into place after adhesive develops strings when touched, typically 1-1/2 to 2 minutes after adhesive was applied, and roll with a weighted roller. Add temporary weight and use relief cuts to ensure boards are well adhered. Stagger the joints of additional layers by a minimum of 6 inches (152 mm).

### 3.7 MEMBRANE PLACEMENT AND ATTACHMENT (Fully Adhered)

- A. Unroll and position membrane without stretching. Allow the membrane to relax for approximately 1/2 hour before bonding. Fold the sheet back onto itself so half the underside of the membrane is exposed.
- B. Apply the Bonding Adhesive in accordance with the manufacturer's published instructions, to both the underside of the membrane and the substrate. Allow the adhesive to dry until it is tacky but will not string or stick to a dry finger touch.
- C. Roll the coated membrane into the coated substrate while avoiding wrinkles. Brush down the bonded half of the membrane sheet with a soft bristle push broom to achieve maximum contact.
- D. Fold back the unbonded half of the membrane sheet and repeat the bonding procedure.
- E. Install adjoining membrane sheets in the same manner, overlapping edges appropriately to provide for the minimum splice width. It is recommended that all splices be shingled to avoid bucking of water.
- F. When positioning membrane sheets, exercise care to locate all field splices away from low spots and out of drain sumps. All field splices should be shingled to prevent bucking of water.

### 3.8 MEMBRANE SPLICING (Tape Splice)

- A. Overlap adjacent sheets and mark a line 1/2 inch (13 mm) out from the top sheet.
- B. Fold the top sheet back and clean the dry splice area a minimum of 3 inches (76 mm) on both membrane sheets.

**University Hall Roof Renovation  
Montclair State University**

---

- C. Apply Primer to the mating surfaces with a scrub pad, at a rate of approximately 450 square feet per gallon for a 3 inch (76 mm) wide seam, and allow to dry.
- D. Apply 3 inch (76 mm) wide Seam Tape to bottom sheet with the edge of the release film along the marked line. Press tape onto the sheet using hand pressure. Overlap tape roll ends a minimum of 1 inch (25 mm).
- E. Remove the release film and press the top sheet onto the tape using hand pressure.
- F. Roll the seam toward the splice edge with a 2 inch (51 mm) wide steel roller.
- G. Install QA "T" Joint Cover, a 6 inch wide (152 mm) section of VersiGard QA Flashing or VersiGard Non-QA Flashing over all field splice intersections. When using Non-QA Flashing, seal edges of flashing with Lap Sealant.
- H. The use of Lap Sealant with tape splices is optional except at tape overlaps and cut edges of reinforced membrane where Lap Sealant is required.

### 3.9 FLASHING

- A. Wall and curb flashing shall be cured EPDM membrane. Continue the deck membrane as wall flashing where practicable.
- B. Follow manufacturer's typical flashing procedures for all wall, curb, and penetration flashing including metal edging/coping and roof drain applications.

### 3.10 WALKWAYS

- A. Install walkways at all traffic concentration points (such as roof hatches, access doors, rooftop ladders, etc.) and all locations as identified on the Contract Drawings.
- B. Adhere walkway pads to the EPDM membrane in accordance with the manufacturer's current application guidelines.

### 3.11 DAILY SEALS

- A. On phased roofing, when the completion of flashings and terminations is not achieved by the end of the work day, a daily seal shall be performed to temporarily close the membrane to prevent water infiltration.
- B. Use Pourable Sealer or other acceptable membrane seal in accordance with the manufacturer's requirements.

### 3.12 CLEAN UP

- A. Perform daily clean-up to collect all wrappings, empty containers, paper, and other debris from the project site. Upon completion, all debris shall be disposed of in a legally acceptable manner.
- B. Prior to the manufacturer's inspection for warranty, the applicator shall perform a pre-inspection to review all work and to verify all flashing has been completed as well as the application of all caulking.

### 3.13 PROTECTION

**University Hall Roof Renovation  
Montclair State University**

---

- A. Provide protection, such as 3/4 inch (19 mm) thick plywood, for all roof areas exposed to traffic during construction. Plywood must be smooth and free of fasteners and splinters.
- B. Protect installed products until completion of project.
- C. Touch-up, repair or replace damaged products before Substantial Completion.

END OF SECTION

MANUFACTURER  
HUNTER PANELS  
15 FRANKLIN STREET  
PORTLAND, MAINE  
04101  
888-746-1114



**TAPERED SYSTEM PROPERTIES**

TAPERED PANELS: VERSICORE 20 PSI  
FILL PANELS: VERSICORE 20 PSI  
MIN. THICKNESS: 0.5"  
MAX. THICKNESS: 7.4"  
SLOPE (in/ft): 1/4", 1/2"

CRICKET PANELS: VERSICORE 20 PSI  
FILL PANELS: VERSICORE 20 PSI  
MIN. THICKNESS: N/A  
MAX. THICKNESS: N/A  
SLOPE (in/ft): N/A

R-VALUE PER INCH: 5.7  
MINIMUM R-VALUE: 2.9  
AVERAGE R-VALUE: 23.90

ALL MATERIAL IS 4' x 4' UNLESS OTHERWISE NOTED

PROJECT

**Montclair State University -  
University Hall - 2nd Floor**

Upper Montclair, New Jersey

DISCLAIMER

THE SHOP DRAWINGS PROVIDED HEREIN ARE BASED ON THE TAPERED DEPARTMENT'S INTERPRETATION OF THE INFORMATION AVAILABLE AT THE TIME OF CREATION AND ARE INTENDED FOR LAYOUT PURPOSES ONLY. CONTRACTORS MUST VERIFY THE LAYOUT AGAINST SITE CONDITIONS AND ENSURE COMPLIANCE WITH LOCAL/STATE CODE.

WE HAVE REVIEWED AND APPROVE THIS TAPERED INSULATION LAYOUT WITH RESPECT TO THE DRAINAGE SPECIFIED IN THE PROJECT DOCUMENTS AND COMPATIBILITY WITH EXISTING FIELD CONDITIONS; SPECIFICALLY, BUILDING DIMENSIONS AND ROOF DRAIN-UNIT LOCATIONS.

\_\_\_\_\_  
SIGNATURE DATE

DATE: 03/11/2025

DESIGNER: James Singer

SCALE: 3/16" = 1'-0"

PROJECT NUMBER

**89009F01**

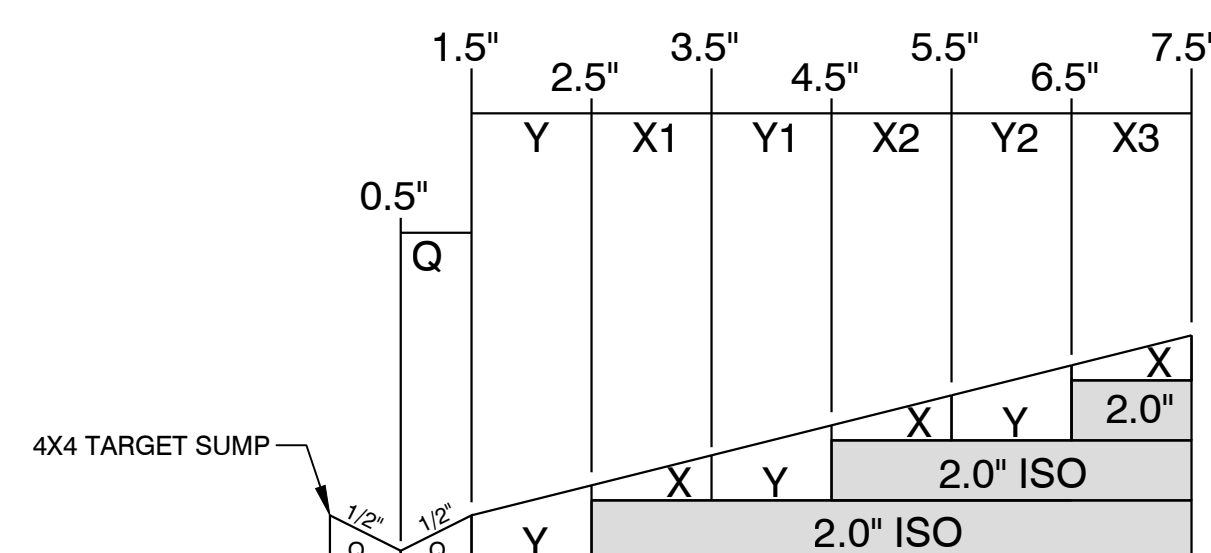
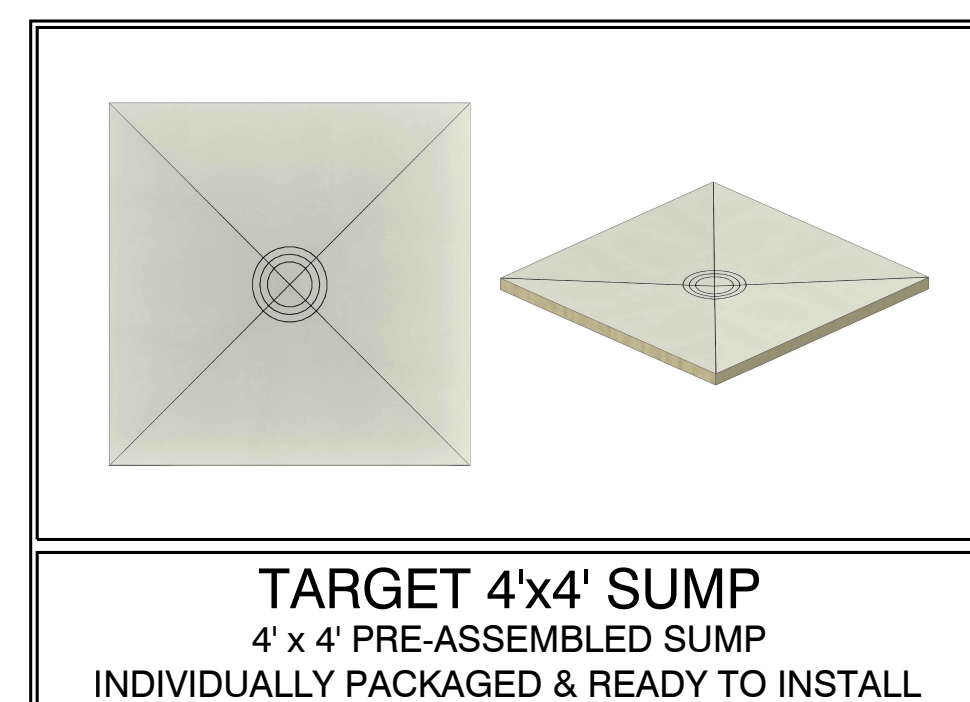
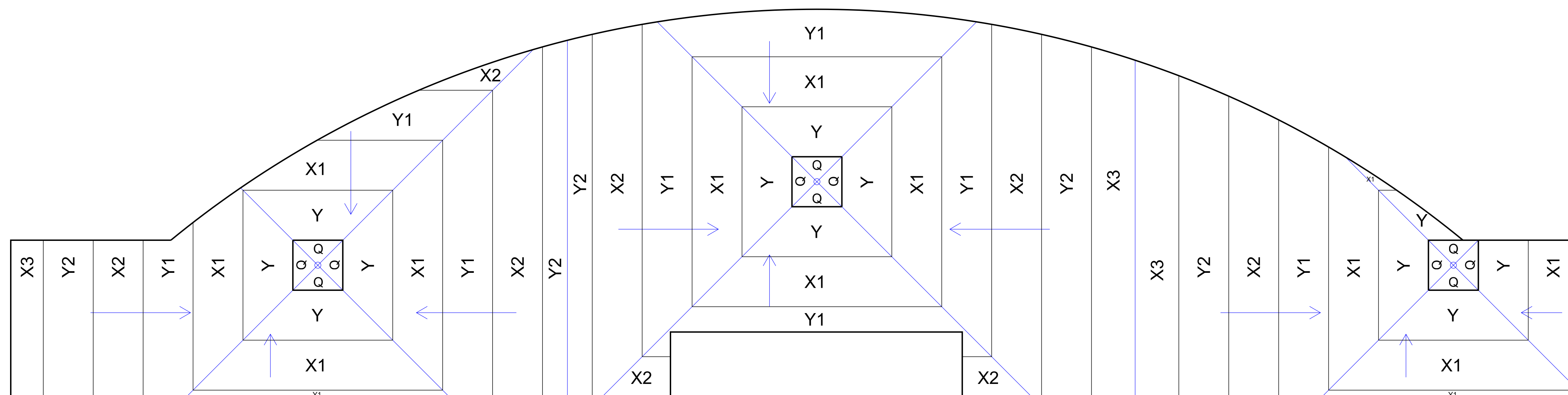

**1 PROFILE VIEW OF TAPER**  
1/4" TAPER SLOPE Scale: NTS

DRAWING LEGEND	
	INDICATES DRAIN SUMP - SEE DRAIN SUMP DETAIL
	INDICATES DRAINAGE DIRECTION USING TAPERED INSULATION